

BIG Green HVAC Truck

Multi-Use Hand Truck by

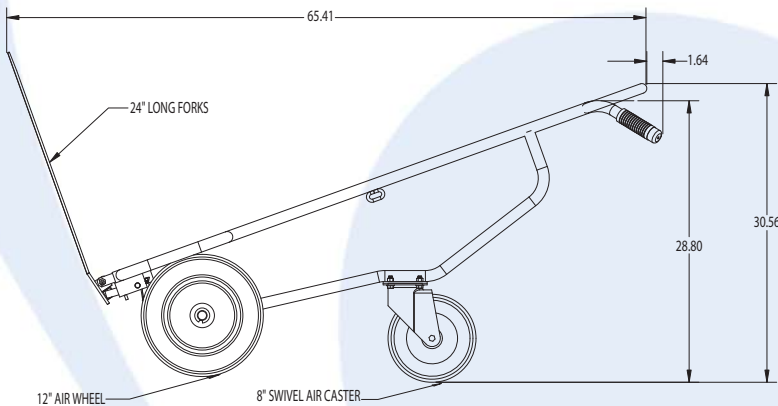

Make handling those large bulky heating and cooling units safer and easier with an ergonomic hand truck designed for efficiency and built for durability. The 4-wheel design with loop handle makes transporting oversized loads a much more efficient task by increasing productivity and decreasing the chance for damage.



Optional Strapping Attachment

Model F80234B6



Model F80233C7 multi-use hand truck easily handles up to 600 lbs.

24"-long forks allow for safe loading and unloading of large heating and air conditioning units, or any other large palletized load, while over-sized fenders stabilize the load. The foot-activated trip pedal locks and unlocks fork position. Simply slide the angled truck forks under the load, tilt forward to lock forks in place and break-over the load. Forks lock against the frame for compact storage.

- Designed with Valley Craft's patented EZY-Tilt™ system in mind
- Available in green, red or blue
- Optional retractable strapping attachment available
- 1 1/8" heavy wall steel tube frame
- Forks lock automatically
- Rolls easily on pneumatic tires



Made in the U.S.A.



2001 South Highway 61 ▪ Lake City, MN 55041

Phone: (800) 328-1480 ▪ (651) 345-3386

Fax: (651) 345-3606

valleycraft.com ▪ customer@valleycraft.com